

Henry Williams - A Division of Trackwork Limited
Darlington
Co. Durham
DL1 2NJ
(01325) 462 722

www.hwilliams.co.uk



SafeBox Class II Compact Range

Operation & Maintenance Manual

Document Ref: HWC2SafeBoxCMP Issue: 3.0



Issue and Revision Record

Rev	Date	Originator (Print) (Signature)	Checker (Print) (Signature)	Description
1.0	11/08/15	D Hughes	C Stephenson	First Issue
1.1	27/10/15	D Hughes	C Stephenson	NWR 1st Review Comments Added
2.0	19/01/22	C Stephenson	P Davies	Section 6 - Part Numbers updated
3.0	04/02/25	P Davies	C Stephenson	Company changed to Henry Williams - A Division of Trackwork Limited

List of Contents – Chapters and Appendices

1	Introduction	5
1.1	Maintenance Policy	5
1.1.1	Complete Replacement	5
1.1.2	Component Repair	5
1.2	Competencies and Training Requirements	6
1.3	Glossary of Terms and Abbreviations	6
1.4	Drawing References of SafeBox Compact Range	7
2	Safety	8
2.1	Isolation and Risk of Electrocution	8
2.2	Class II coating	8
2.3	Class II Definition	8
2.4	Lifting & Trapping	9
2.5	Disposal of Equipment	9
2.6	Fuse Ratings	9
2.7	Surge Protection Device Type	9
2.8	Fault Conditions Required for Electric Shock	9
3	Details of the SafeBox Equipment	10
3.1	General Information	10
3.2	SafeBox Compact Layout/General Arrangement	11
4	SafeBox Compact Installation	13
4.1	SafeBox Mounting	13
4.2	Installation of Incoming/Loop Power Cables (with Power OFF)	14
4.3	Terminating Aluminium Cables	19
4.4	Installation of the Functional Circuits Wiring	19
4.5	Replacement of Incoming or Outgoing Loop Power Cables (Under Operational Conditions)	24
4.6	Load/Transformer Feed Wiring	26
5	Maintenance	27
5.1	Replacement of Components	27
5.2	Annual Procedure	27
5.3	EIC Coating Damage Guidance	28
5.4	Flooding Guidance	30
5.5	Fire Guidance	30

6	Part Numbers	31
7	Guarantee	32

Table of Figures

Figure 1:	SafeBox Compact C32/SA Front Layout Arrangement	11
Figure 2:	SafeBox Power In/Out Terminal Arrangement	12
Figure 3:	Functional Circuits/Transformer Wiring Outlets	12
Figure 4:	BRS-SM 440 Fixing Kit [M4]	13
Figure 5:	Cable Gland Plate removed from the enclosure	15
Figure 6:	Cable length marked ready for cutting	15
Figure 7:	Cable cut to length	16
Figure 8:	Fit & Crimp Cable Lugs	17
Figure 9:	Refit Gland Plate	17
Figure 10:	Complete Termination	18
Figure 11:	Refit Terminal Covers	18
Figure 12:	Removal of Terminal Cover	20
Figure 13:	Terminal Cover Removed	21
Figure 14:	Fitting of Conduit Gland & Conduit	21
Figure 15:	Functional Wiring Terminated	22
Figure 16:	Transformer Conduit to SafeBox Installation	23
Figure 17:	Final Installation	23
Figure 18:	Ring Cable Diagram	24
Figure 19:	EIC Damage Guide	29

1 Introduction

This document is designed for use by the maintenance staff (technicians and their supervisors) to maintain (fault find, repair or replace) components of the SafeBox and associated components.

Throughout this document, references will be made to other essential information and documentation either prepared by HW or provided from the equipment supplier/manufacturer.

After safety issues are discussed in Chapter 2 this manual follows a logical path from Description of the relevant components, equipment installation, repair/replacement, routine maintenance and finally a spare parts listing.

- **Chapter 2 Safety**
Gives details of any relevant safety issues to be observed in the use and disposal of the equipment.
- **Chapter 3 Details of SafeBox Equipment**
Gives details of the SafeBox enclosure and equipment.
- **Chapter 4 SafeBox Installation**
Gives details on installation of the SafeBox, the power cables, and functional circuit wiring.
- **Chapter 5 Maintenance**
Details the recommended maintenance checks required to ensure the ongoing correct operation of the system.
- **Chapter 6 Part Numbers**
Lists the main parts of the SafeBox System complete with Supplier and Part numbers to aid in the re-ordering of spare parts.

1.1 Maintenance Policy

The SafeBox system comprises highly reliable components. However should a fault occur, the unit can be completely replaced.

1.1.1 Complete Replacement

If the SafeBox is completely replaced, note the following:

Note that this is a Class II unit and must only be replaced by another Class II unit.

1.1.2 Component Repair

Repair of any functional electrical components on-site are not recommended as the unit will normally require disassembly to gain access to the internal components. After any disassembly a Class II insulation integrity test should be carried out. This test requires specialist High Voltage testing equipment to confirm that the Class II insulation is intact and undamaged

This testing should only be carried out by Henry Williams - A Division of Trackwork Limited. who will also supply a product test report upon satisfactory values being obtained.

1.2 Competencies and Training Requirements

Staff with the responsibility for installation and maintenance of the SafeBox must hold the required Network Rail licenses.

The training will provide the skills and knowledge needed to identify faulty modules/components and the correct procedures for their replacement. Training for the repair of line replaceable units (modules) is not available. Line replaceable units, where appropriate will be returned to the manufacturer for repair or replaced from spares where repair is not practical.

1.3 Glossary of Terms and Abbreviations

EIC	Electrically Insulated Coating
Class II	See definition in Section 2.3
HW	Henry Williams - A Division of Trackwork Limited
Kg	Kilograms
Loc	Location/Location Case
mm	millimetres
Nm	Newton metres
REB	Relocatable Equipment Building
SafeBox	Enclosure containing integrated electrical components
VAC	Voltage (AC) Alternating Current

1.4 Drawing References of SafeBox Compact Range

SafeBox Model	Wiring Schematic Drawing Ref	General Arrangement Drawing Ref:
SafeBox Compact C11	23380-C11-II-W-B	HWE-SAFEBOX-C11
SafeBox Compact C12	23380-C12-II-W-B	HWE-SAFEBOX-C12
SafeBox Compact C13	23380-C13-II-W-B	HWE-SAFEBOX-C13
SafeBox Compact C22	23380-C22-II-W-C	HWE-SAFEBOX-C22
SafeBox Compact C22/SA	23380-C22/SA-II-W-B	HWE-SAFEBOX-C22/SA
SafeBox Compact C32	23380-C32-II-W-B	HWE-SAFEBOX-C32
SafeBox Compact C32/SA	23380-C32/SA-II-W-B	HWE-SAFEBOX-C32/SA
SafeBox Legacy SL11/A	23380-SL11/A-II-W-A	HWE-SAFEBOX-SL11/A
SafeBox Legacy SL11/B	23380-SL11/B-II-W-A	HWE-SAFEBOX-SL11/B
SafeBox Legacy SL11/C	23380-SL11/C-II-W-A	HWE-SAFEBOX-SL11/C
SafeBox Terminal Enclosure HW/T1	N/a	HWE-SAFEBOX-HW/T1
SafeBox Terminal Enclosure HW/T2	N/a	HWE-SAFEBOX-HW/T2
SafeBox Terminal Enclosure HW/T3	N/a	HWE-SAFEBOX-HW/T3
SafeBox Compact Split CSP11	23380-CSP11-II-W-A	HWE-SAFEBOX-CSP11
SafeBox Compact Split CSP12	23380-CSP12-II-W-A	HWE-SAFEBOX-CSP12
SafeBox Compact Split CSP13	23380-CSP13-II-W-A	HWE-SAFEBOX-CSP13
SafeBox Compact Split CSP22	23380-CSP22-II-W-A	HWE-SAFEBOX-CSP22
SafeBox Compact Split CSP22/SA	23380-CSP22SA-II-W-A	HWE-SAFEBOX-CSP22/SA
SafeBox Compact Split CSP32	23380-CSP32-II-W-A	HWE-SAFEBOX-CSP32
SafeBox Compact Split CSP32/SA	23380-CSP32/SA-II-W-A	HWE-SAFEBOX-CSP32/SA
SafeBox Legacy Split LSP11	23380-LSP11-II-W-A	HWE-SAFEBOX-LSP11

2 Safety

2.1 Isolation and Risk of Electrocutation

The SafeBox is designed to work with voltages up to (and including) 650VAC and as such there is a danger of electrocution once the cover is removed.

All electrical power feeds to the SafeBox MUST be ISOLATED and LOCKED OFF BEFORE opening any doors or removal of the enclosure cover.

A 650VAC supply voltage is commonly used inside the signalling cubicles, and any personnel working inside these units should be appropriately trained. It should also be noted that the SafeBox units are designed to be mounted inside a locked enclosure, which is in a protective environment (Signalling Cubicle or REB) and have large caution labels clearly visible from the front.

Personnel working on the SafeBox should be appropriately trained to work with dangerous voltages and be fully conversant with the power circuitry. All connections are shrouded to prevent accidental contact with personnel (fingers etc.) however these voltage may be exposed when using tools such as screwdrivers etc.

Once Isolation has been carried out, it is essential that a proved* voltage indicator is used to recheck that all electrical equipment is dead prior to any works being undertaken.

* It is recommended to use a proving device with the voltage indicator to check for correct operation both before and after checking that the equipment to be worked upon is dead.

2.2 Class II coating

The product is coated with a special Electrically Insulated Coating (EIC) which can withstand very high voltages. This coating must remain intact in order to ensure the integrity of the insulation properties of the enclosure. There must therefore be no further holes or other cut-outs made into the enclosure body post manufacture.

2.3 Class II Definition

A Class II or double insulated electrical appliance is one which has been designed in such a way that it does not require a safety connection to electrical earth.

The basic requirement is that no single failure can result in dangerous voltage becoming exposed so that it might cause an electric shock and that this is achieved without relying on an earthed metal casing.

This is usually achieved at least in part by having two layers of insulating material surrounding live parts or by using reinforced insulation.

2.4 Lifting & Trapping

The SafeBox units are fairly heavy (approx. 15Kg to 40Kg depending upon model) and extra care should be exercised when handling these units. The Manual Handling Regulations should be taken into account when lifting heavy items. Due to the obstructions underfoot in track areas, it is recommended that the removal and/or replacement of a SafeBox unit should be carried out with a minimum of two people.

There is a risk of trapping of fingers when the cover is repositioned over the body of the SafeBox unit. It is recommended that one person positions and holds the cover whilst a second person installs the fixing screws.

2.5 Disposal of Equipment

Due consideration must be given when disposing of equipment.

Environmental regulations and standards are continually being updated and therefore a risk assessment must be undertaken at the time of equipment disposal.

None of the SafeBox components contain batteries or other toxic materials.

Although the Class II coating and other materials used in the equipment are designed to release low smoke and less toxic fumes when burnt, burning of this equipment, as a means of disposal is not appropriate.

<p style="text-align: center;">The equipment must be disposed of in accordance with the Waste Electrical and Electronic Equipment (WEEE) Regulations</p>

2.6 Fuse Ratings

All fuses installed into the SafeBox fuse carriers must be rated to 690VAC.

2.7 Surge Protection Device Type

Only two-wire type surge protection devices can be used with the Class II SafeBox. See spares list for standard type installed.

2.8 Fault Conditions Required for Electric Shock

Note that in order for a person to receive an electric shock (with the box closed) the following simultaneous fault conditions must exist:

- The outer coating must be penetrated/damaged (at least to bare metal).
- The inner coating must be penetrated/damaged (at least to bare metal).
- An internal electrical fault must occur so that a live conductor touches exactly the same area where the inner coating is exposed to bare metal.
- The person must make contact with exactly the same area where the outer coating is exposed to bare metal.

3 Details of the SafeBox Equipment

3.1 General Information

The SafeBox Compact range is a Class II 650VAC distribution system in a single enclosure. It is designed to be fixed to standard BRS SM 440 rails as found in location cases, REBs and other railway enclosures. It can also be fitted to any flat surface if required using standard M8 fixings.

The SafeBox Compact is designed to be the unit which will terminate the incoming and outgoing 650VAC power loop cables.

The unit is designed so that the incoming and outgoing loop feeder cable terminals are housed in separate compartments. This allows one cable to be isolated and safely worked on whilst the other is still live and powering the location signalling equipment.

The SafeBox Compact also has over-current protected outgoing ways which can be used to feed 650VAC to the local transformers which in turn feed the signalling system.

The enclosure is manufactured from stainless steel which is completely covered in a special insulated paint. This insulation gives the enclosure its Class II protection properties.

The SafeBox Compact can also house an optional 650VAC suppression module should this be required. Note that only two-wire type surge protection devices can be used with the Class II SafeBox.

3.2 SafeBox Compact Layout/General Arrangement

The photograph below shows the general layout of the SafeBox Compact. This general layout is similar for all of the SafeBox Compact models.

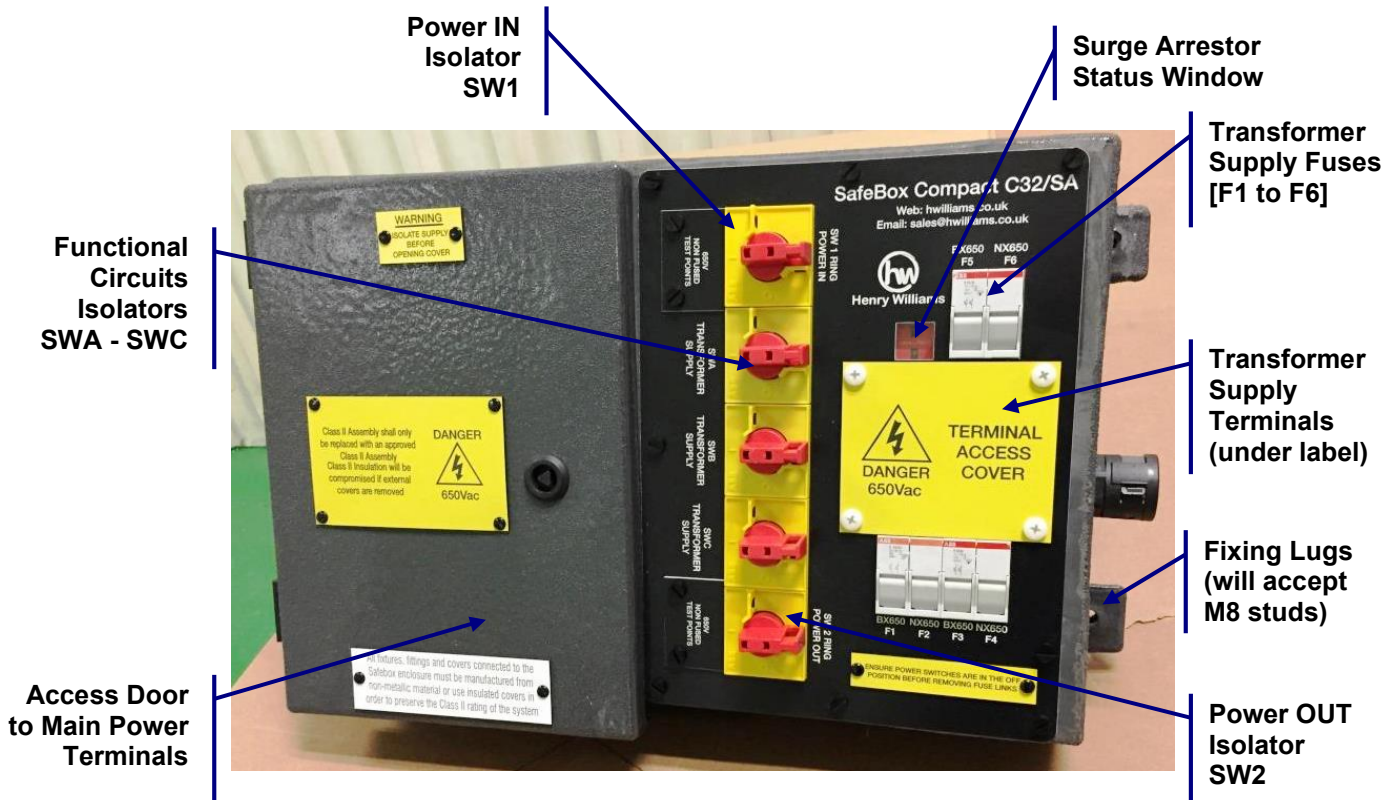

Figure 1: SafeBox Compact C32/SA Front Layout Arrangement

Figure 1 shows the general layout applicable to the SafeBox Compact models no. range C11, C12, C13, C22, C22/SA, C32, and C32/SA

Note that the model shown in figure 1 is a C32/SA which has both a Power IN and a Power OUT isolator. Some models may only use one “mains” isolator. Refer to the particular model drawings in the table in Section 1.4.

Some models may have any number (from 1 to 3) of functional circuit Isolators installed. If a surge arrester is fitted (defined by /SA appended to the model number) then one of the functional switches and two of the fuses will be used for the power feed to it.

In the case of a model C22/SA, functional switch (SWB) and the two fuses (F3 & F4) will be used for the Surge Arrester supply.

In the case of a model C32/SA, functional switch (SWC) and the two fuses (F5 & F6) will be used for the Surge Arrester supply.

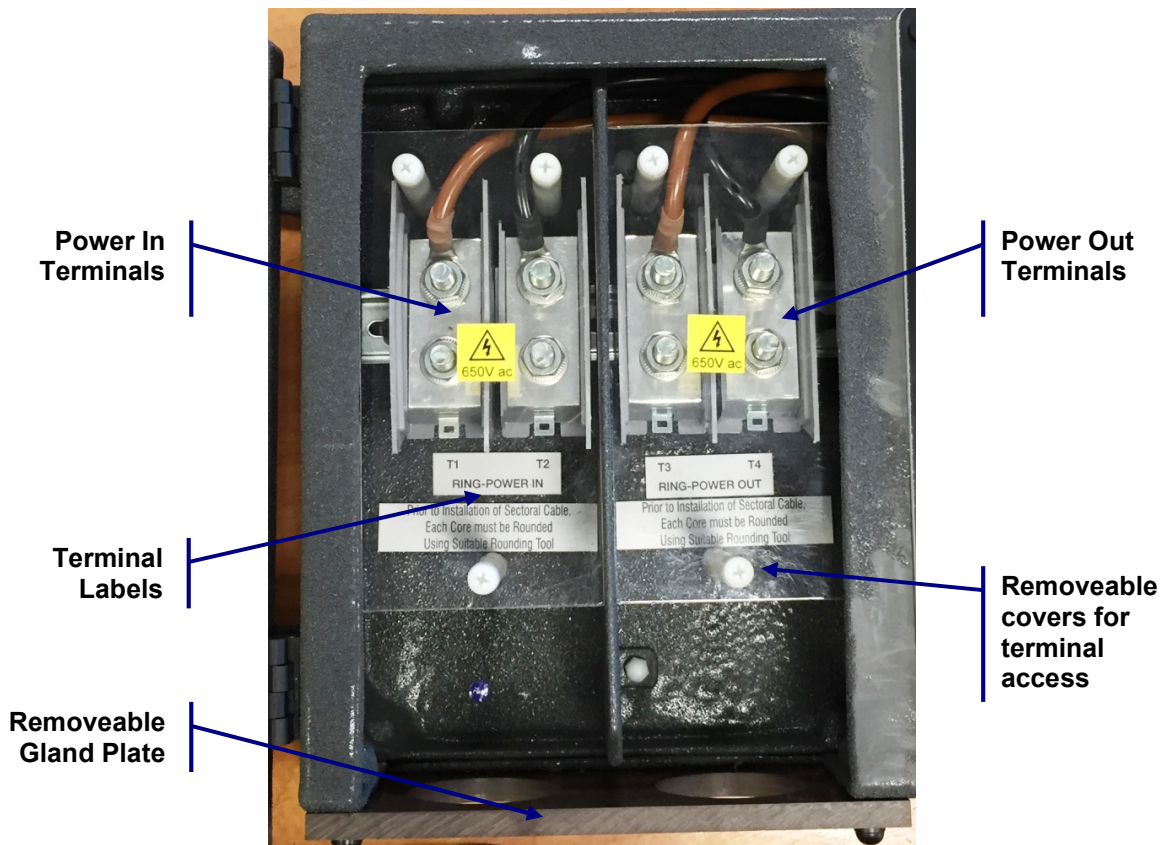

Figure 2: SafeBox Power In/Out Terminal Arrangement



Figure 3: Functional Circuits/Transformer Wiring Outlets

4 SafeBox Compact Installation

The following sub-sections detail the instructions for installation of the SafeBox into a variety of enclosures.

The SafeBox can be installed into the following:

- Railway location case
- REB racking
- Marine ply backboard

4.1 SafeBox Mounting

All SafeBox Compact enclosures have mounting tabs fitted to the top and bottom at each side. These have a nylon insert to protect the tab and are overcoated with the EIC coating material to enhance the insulation properties.

These pre-drilled holes are designed to accept M8 fixings.

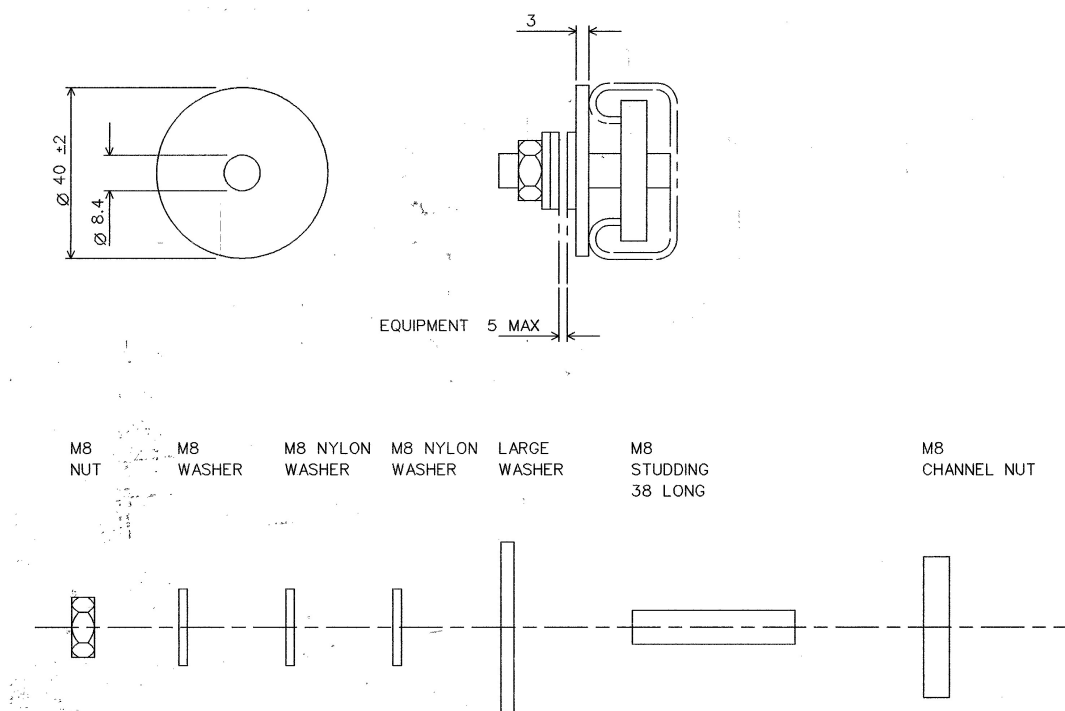

Figure 4: BRS-SM 440 Fixing Kit [M4]

For BRS-SM 440 fixings use an M4 fixing kit which is shown in Figure 4.

M4 fixing kit: CAT No. 086/43556.

The SafeBox model series can be rear mounted directly onto the BRS-SM440 mounting rails.

Note that the incoming cable diameters and minimum bending radius must be observed when mounting the SafeBox into any enclosure.

As a good guide for any size cable, it is recommended to mount the SafeBox at a height of 500mm from the floor/base plinth of the enclosure.

4.2 Installation of Incoming/Loop Power Cables (with Power OFF)

The SafeBox range has been designed to accommodate power cables up to 120mmsq. The terminal studs are 10mm and the correctly sized cable lugs must be fitted to suit both the cable and the terminal studs.

Installation Sequence:

1. Remove the gland plate from the bottom of the terminal chamber – see Figure 5.
2. Install Stripped Cable into gland & tighten.
3. Install gland plate back onto the bottom of the terminal chamber.
4. Fit crimp lugs loosely onto terminals and mark cable for cut – see Figure 6.
5. Remove gland plate fixings & pull forward for easier access to cut cable tails to length – see Figure 7.
6. Using a rounding crimp tool, round the copper conductors to accept the crimp lugs.
7. Fit the crimp lugs and crimp cable tails – see Figure 8.
8. Refit gland plate to bottom of the SafeBox enclosure – see Figure 9.
9. Install cable lugs onto terminals, fit washers/nuts & tighten – see Figure 10.
10. Refit terminal protective covers – see Figure 11



Figure 5: Cable Gland Plate removed from the enclosure



Figure 6: Cable length marked ready for cutting



Figure 7: Cable cut to length



Figure 8: Fit & Crimp Cable Lugs



Figure 9: Refit Gland Plate



Figure 10: Complete Termination



Figure 11: Refit Terminal Covers

4.3 Terminating Aluminium Cables

The main terminal studs (10mm) in the terminal chambers may be used to also connect aluminium cables.

Aluminium cables must be connected to the termination studs using suitable cable lugs which must be in conformance with Network Rail standard NR/L2/SIGELP/27423 'Product Specification for Connectors and Joints for Signalling Power Systems using Aluminium Cable'.

Non circular (sector shaped aluminium conductors) may require pre-rounding using die-sets prior to introduction of the conductor into the cable lugs.

Aluminium lugs usually feature barrels capped and filled with grease to prevent oxidation of the aluminium.

Compression (crimp) lugs are an established method of connecting and terminating aluminium cable conductors. To ensure a reliable crimp connection or termination, the following should be observed:

- Both cable conductor and compression crimp lug should be cleaned down using cable cleaning wipes.
- The size, shape and metal (copper or aluminium) must be correct for the cable conductor.
- The correct crimp die set should be selected.
- The cable conductor must be fully inserted into the crimp lug.
- The correct compression or crimping sequence must be followed and the full compression pressure applied.

Failure to observe these precautions can result in a compression connector, lug or termination that fails in service.

The manufacturers' instructions must be carefully followed to ensure that aluminium conductors are correctly terminated to the connection studs inside the SafeBox main terminal chambers.

4.4 Installation of the Functional Circuits Wiring

The SafeBox fuses and terminals are numbered to correspond with the electrical schematic diagram for the relevant model. The electrical schematic diagram (which matches the model being installed) must be consulted before terminations are carried out to ensure the correct connections are made.

Pre-made access holes (25mm Clearance Diameter) are provided in the top right hand side of the enclosure – see Figure 3. These are installed during the manufacturing process for the fitting of conduit or glands for the securing and protection of the functional circuits wiring.

All fixtures, fittings, and covers connected to the SafeBox enclosure must be manufactured from non-metallic material or use insulated covers in order to preserve the Class-II rating of the system.

Outgoing terminals are provided for connection of the functional circuits wiring within the SafeBox. The outgoing wiring is connected to these terminals which are located underneath the terminal access cover – see Figure 12.



Figure 12: Removal of Terminal Cover

Once the terminal cover is removed, access can be gained to the outgoing (functional circuits) terminations – see Figure 13.



Figure 13: Terminal Cover Removed



Figure 14: Fitting of Conduit Gland & Conduit

Figure 14 shows the fitting of a 25mm Class II conduit gland and 25mm conduit into one of the SafeBox outlets.

In order to keep the Class II integrity of this product, it is essential that any unused outlets must be fitted with the insulated hole blanking plugs. Spares are available. See parts list in Section 6.

This conduit is installed into the outlets provided in the SafeBox, with the other end connected to a gland usually into a transformer or rectifier housing.

This conduit and corresponding glands must comply with Network Rail Specifications NR/L2/SIGELP/27422 (Conduit Glands) and NR/L2/SIGELP/27421 (Flexible Conduit).



Figure 15: Functional Wiring Terminated

The functional circuits wiring can be terminated into the fuseholder terminals as shown in Figure 15 above.

Wire connection information for the IEC fuseholders:

- **Wire Stripping Length: 12mm**
- **Screw Tightening Torque: 2.0 – 2.5Nm**

Some SafeBox models may have separate terminals for the termination of the functional circuits wiring. The detail regarding these connections will be shown on the wiring diagram for each specific model.

Once the connections for the functional circuits are complete, the SafeBox terminal access cover can be replaced.



Figure 16: Transformer Conduit to SafeBox Installation

All fuses installed into the SafeBox fuseholders MUST be rated to 690VAC



Figure 17: Final Installation

4.5 Replacement of Incoming or Outgoing Loop Power Cables (Under Operational Conditions)

If the SafeBox model is designed so that the incoming and outgoing loop feeder cable terminals are housed in separated compartments. This will allow one cable to be isolated and safely worked on whilst the other is still live and powering the location signalling equipment.

Once Isolation has been carried out, it is essential that a proved* voltage indicator is used to recheck that all electrical equipment is dead prior to any works being undertaken.

* It is recommended to use a proving device with the voltage indicator to check for correct operation both before and after checking that the equipment to be worked upon is dead.

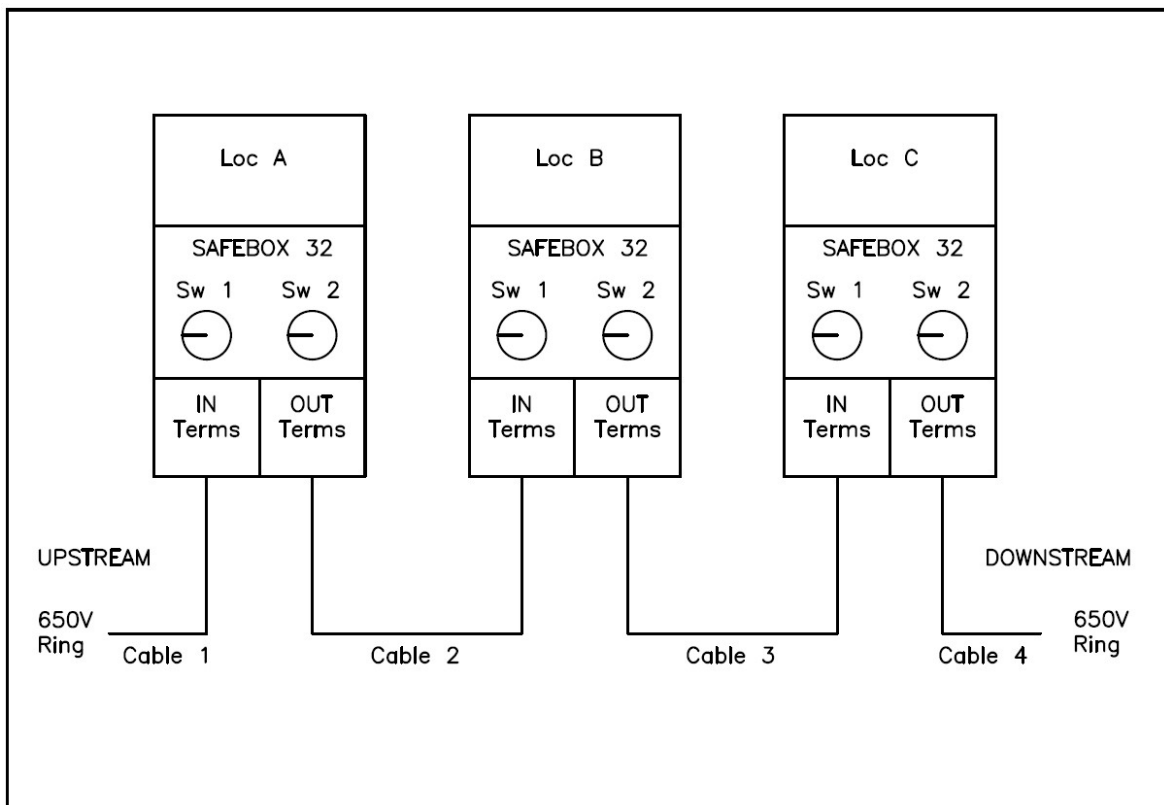

Figure 18: Ring Cable Diagram

The above diagram shows three location cases, each one fitted with a SafeBox (Model 32) to terminate and distribute the 650V ring & local cables. The local transformer feed isolators (SWA to SWC) are not shown in the above simplified diagram as the intention here is to focus on replacing the mains feeder loop cables.

As a general rule, the main incoming switch (UPSTREAM) is labelled SW1 and the outgoing switch (DOWNSTREAM) is labelled SW2. To try and avoid any confusion, the

transformer/load feed switches are usually identified with letters i.e. SWA to SWB for the SafeBox (Model 32). However this may not always be the case as client requirements/project specifications may require alternate switch references.

Each cable is terminated into one of the SafeBox main terminal chambers (either IN Terms or OUT Terms in the above diagram). The SafeBox internal busbar arrangement (and hence local transformer feeds) can be powered by either cable or both cables if they are both live i.e. part of the mains ring.

Examples of Isolation Scenarios

In the following example scenarios, please refer to the associated ring cable diagram given in Figure 18.

Note that the Switch Numbers given below refer to SafeBox model 32. The Switch numbers may be different depending upon the FSP model installed.

It is essential to refer to the correct model wiring diagram before operating any of the SafeBox isolation switches.

Scenario Example 1 - Complete Isolation of Location B SafeBox

In order to fully isolate the SafeBox in location case B then both cable 2 & cable 3 must be isolated from all sources of supply. This can be accomplished by switching OFF and locking OFF, switch 2 in Loc A (UPSTREAM of Loc B) and also switch 1 in Loc C (DOWNSTREAM of Loc B).

It is also essential to check that there is no power being backfed (through switches SWA to SWC) from the local transformer supplies into the SafeBox unit.

Scenario Example 2 - Replacement of Cable 3

Provided the above system is part of a complete closed ring main system (i.e. power fed from both ends) then Cable 3 can be replaced without losing power to any of the three location cases.

In the diagram shown in Figure 18 Cable 3 must first be isolated from all sources of supply by switching OFF & locking OFF switch 2 in Loc B (UPSTREAM of Cable 3) and also switch 1 in Loc C (DOWNSTREAM of Cable 3).

In the SafeBox in Loc B the terminal chamber door to "OUT Terms" can now be opened allowing access to the terminations for cable 3. These terminations have a safety shroud fitted which must be removed to gain full access to the terminal securing bolts once the equipment is proved dead.

The covering safety shroud has two small holes which allow the user to ensure the terminals are dead (by use of a suitable proved test indicator) before removal of the shroud.

Similarly the SafeBox in Loc C the terminal chamber door to "IN Terms" can now be opened allowing access to the terminations for the other end of cable 3. These

terminations also have a safety shroud fitted which must be removed to gain full access to the terminal securing bolts once the equipment is proved dead.

Scenario Example 3 - Replacement of Cable 2

Provided the above system is part of a complete closed ring main system (i.e. power fed from both ends) then Cable 2 can be replaced without losing power to any of the three location cases.

In the diagram shown in Figure 18 Cable 2 must first be isolated from all sources of supply by switching OFF & locking OFF switch 2 in Loc A (UPSTREAM of Cable 2) and also switch 1 in Loc B (DOWNSTREAM of Cable 2).

In the SafeBox in Loc A the terminal chamber door to “OUT Terms” can now be opened allowing access to the terminations for cable 2. These terminations have a safety shroud fitted which must be removed to gain full access to the terminal securing bolts once the equipment is proved dead.

The covering safety shroud has two small holes which allow the user to ensure the terminals are dead (by use of a suitable proved test indicator) before removal of the shroud.

Similarly the SafeBox in Loc B the terminal chamber door to “IN Terms” can now be opened allowing access to the terminations for the other end of cable 2. These terminations also have a safety shroud fitted which must be removed to gain full access to the terminal securing bolts once the equipment is proved dead.

4.6 Load/Transformer Feed Wiring

The signalling loads/transformers wiring is connected into the terminals installed under the cover label in the top right-hand corner of the SafeBox unit – See Figure 1.

It is essential that the SafeBox is fully isolated and locked off from all supplies (See Scenario Example 1 above) **before** the terminal cover is removed.

Once Isolation has been carried out, it is essential that a proved* voltage indicator is used to recheck that all electrical equipment is dead prior to any works being undertaken.

* It is recommended to use a proving device with the voltage indicator to check for correct operation both before and after checking that the equipment to be worked upon is dead.

Once the equipment is proven to be dead, access can be gained to these terminals to install or replace load cables as required.

5 Maintenance

All electrical power feeds to the SafeBox MUST be ISOLATED and LOCKED OFF prior to the opening any doors or removal of the enclosure cover.

5.1 Replacement of Components

Replacements of any of the functional electrical components on-site are not recommended as the unit will normally require disassembly to gain access to the internal components. After any dis-assembly a Class II insulation integrity test should be carried out. This test requires specialist High Voltage testing equipment to confirm that the Class II insulation is intact and undamaged

This testing should only be carried out by Henry Williams - A Division of Trackwork Limited. who will also supply a product test report upon satisfactory values being obtained.

5.2 Annual Procedure

It is recommended that the following work be carried out yearly:

- General visual inspection as to the condition of the enclosure and components within (including wiring).
- Check that the Electrically Insulated Coating (EIC) does not show any signs of damage and in particular any exposure of the metal base material that this damage caused. See guidance given in Section 5.3
- Check presence & legibility of all I.D. labelling and warning notices.
- Check all cable connections and crimps are secure and do not show any sign of heat/burning.
- Check that all fuses are present and of the correct size (and voltage rating on 650VAC) as detailed on the electrical schematic diagrams.
- Remove, inspect, and re-insert fuses. Check carrier tightness & for signs of any burning.
- Ensure all fixing nuts, washers, bolt covers etc. are present, correct, and tight.
- Check cables and glands box for damage or evidence of water ingress.
- Give the equipment a general clean and remove any build-up of dust/debris using a brush or small nozzled vacuum.
- Before being returned to service, it is recommended to carry out an operational check of the isolation switches.

Note that this is a Class II unit and if completely replaced, it must only be replaced by another Class II unit.

5.3 EIC Coating Damage Guidance

As the coating is applied to both the inside and the outside of the inner stainless steel enclosure body, the outer coating can take some acceptable damage before the unit requires replacing.

Note that in order for a person to receive an electric shock (with the box closed) the following simultaneous fault conditions must exist:

- The outer coating must be penetrated/damaged (at least to bare metal).
- The inner coating must be penetrated/damaged (at least to bare metal).
- An internal electrical fault must occur so that a live conductor touches exactly the same area where the inner coating is exposed to bare metal.
- The person must make contact with exactly the same area where the outer coating is exposed to bare metal.

Figure 19 shows a practical guide which has been developed by Henry Williams to help maintenance personnel understand what levels of damage are acceptable and which are not.

As can be seen below the damage guide is split up into three action levels:

Action Level 1

The amount of damage is superficial and does not completely penetrate the outer coating. This level of damage should be noted on the maintenance sheet along with its location. The damage can then be monitored during future inspections to ensure that no further worsening occurs.

It is not recommended to increase the frequency of visual inspections for this level of damage.

Action Level 2

The amount of damage is worse than that in action level 1 in that it does completely penetrate the outer coating. This level of damage should be noted on the maintenance sheet along with its location. The damage can then be monitored during future inspections to ensure that no further worsening occurs.

The unit can be put back into service with an affixed label/notice indicating what damage has been observed.

It is recommended to increase the frequency of visual inspections for this level of damage to ensure that there is no further degradation in the coating.

Action Level 3

The amount of damage is much worse than that in action level 2 in that the enclosure is completely penetrated through both the inner & outer coatings and the stainless steel body. This level of damage should be noted on the maintenance sheet along with its location.

The unit can be put back into service with an affixed warning label/notice indicating what damage has been observed.

It is recommended to replace the unit at the next available opportunity.

Note that the EIC Coating is a NON-REPAIRABLE item

Henry Williams
Henry Williams Ltd
Dodsworth Street, Darlington, DL12 2NJ
Tel: 01325 462722 Fax: 01325 245220
Web: www.hwilliams.co.uk Email: sales@hwilliams.co.uk

**HENRY WILLIAMS
SAFEBOX APPLICATION**

E I C DAMAGE GUIDE

THE GRID BELOW IS DESIGNED TO PROVIDE A GUIDE AS TO WHAT ACTION IS TO BE TAKEN WHEN CONFRONTED WITH EXTERNAL COATING DAMAGE. ALL SCENARIOS ARE NOT COVERED AND ADVICE SHOULD BE SOUGHT FROM **HENRY WILLIAMS LTD** IF YOU ARE UNSURE HOW TO PROCEED

ACTION LEVEL 1
DO NOTHING BUT RECORD ANY DAMAGE FOR FURTHER INSPECTION AND MONITORING

ACTION LEVEL 2
UNIT CAN BE RETURN TO SERVICE WITH DAMAGED CLEARLY LABELLED. INCREASE LEVEL OF INSPECTION.

ACTION LEVEL 3
UNIT CAN BE RETURN TO SERVICE WITH DAMAGED CLEARLY LABELLED. REPLACE UNIT AT NEXT AVAILABLE OPPORTUNITY.

LIGHT DAMAGE- **ACTION LEVEL 1**
-SURFACE DAMAGED BUT NO METAL EXPOSED



MEDIUM DAMAGE- **ACTION LEVEL 2**
-OUTER COATING LAYER BREACHED BUT METAL STILL IN PLACE

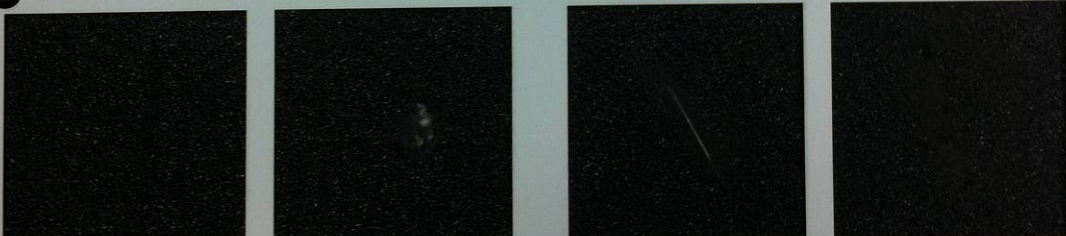

HEAVY DAMAGE- **ACTION LEVEL 3**
-OUTER METAL AND INNER COATING BREACHED



Figure 19: EIC Damage Guide

5.4 Flooding Guidance

The models in the SafeBox range are designed to allow the natural drainage of water after flooding. There are small gaps built into the joins between the partition sections and also between the gland plate and the door bottom flange.

Should flooding occur, we would recommend that the unit not be put back into service unless completely dry. Failing this the unit should be replaced and returned to Henry Williams for repair and retesting.

If there is any doubt, then the unit can be returned to Henry Williams for assessment and for a retest of the insulation integrity.

5.5 Fire Guidance

Where any unit has been involved in a fire which has been substantial enough to compromise the insulating properties of the EIC coating, then it should be replaced.

The EIC coating would be considered as compromised when it shows physical damage or melting of the coating and the enclosure steel can be seen either inside or outside.

If the damage is minor (no underlying metal showing and the coating intact) then the unit can be continued in service.

If there is any doubt, then the unit can be returned to Henry Williams for assessment and for a retest of the insulation integrity.

6 Part Numbers

The table below details the part numbers for the replaceable items used in the SafeBox Compact system along with a description and supplier for each item.

Description	Supplier	Part Number
3 Pole Isolating Switch (80A)	ABB	HWE-SAFEBOX-006 OT80F3 / 1SCA105798R1001
Isolating Switch Red/Yellow Handle & Yellow Shroud	Henry Williams - A Division of Trackwork Limited	HWE-SAFEBOX-001
Stud Terminals (M300/42.FF)	ABB	HWE-SAFEBOX-011 1SNA115149R2000
Main Stud Terminal Block Partition (ECP42)	Henry Williams - A Division of Trackwork Limited.	HWE-SAFEBOX-012 1SNA113692R1700
Through Terminals (Grey M10/10)	ABB/Entelec	HWE-SAFEBOX-013 1SNA115120R1700
Main Stud Terminal Block Clear Safety Cover	Henry Williams - A Division of Trackwork Limited	2014.038-C8-001
20mm Hole Blanking Plug with Locknut	Henry Williams - A Division of Trackwork Limited	HWE-SAFEBOX-031
Door Key (triangular)	Henry Williams - A Division of Trackwork Limited	CON-574
Nut covers (Black/Nylon)	Henry Williams - A Division of Trackwork Limited	CON-563
BRSSM440 M4 Rail Fixing Kit	Henry Williams - A Division of Trackwork Limited	086/43556

* Other spares & Labels may be available upon request.

7 Guarantee

The function and safety of the equipment is only guaranteed if the warning and safety instructions included in this manual are adhered to.

Henry Williams - A Division of Trackwork Limited is not liable for any personal injury to property that occurs as a result of the warning and manual being disregarded.

Henry Williams - A Division of Trackwork Limited do does not accept any liability or warranty for damage due to the use of non-approved spare parts and accessories.