

ITEM	DESCRIPTION	TYPE/MANUFACTURER	PART No.	QUANTITY
A	B1 MILD STEEL LOCATION CASE	HENRY WILLIAMS	2011.076-A1-000	1
B	EARTH BLOCK 12 WAY + DIS LINK	FURSE	LK243-12	1
C	TRANSFORMER T3 CABLE GLAND BOX	RITTAL	KL1529.010	1
D	FUSE CARRIER	CAMASTER	CM63F	4
E	TERMINAL	ENTRELEC	M35/16	2
F	MODULAR ENCLOSURE	MCG	92.08	1
G	TERMINAL BAR SUPPORT	MCG	1006.08	1
H	FUSE HOLDER 1P+N	ABB	2CSM200893R1801	3
J	CLASS 2 POWERBOX	HENRY WILLIAMS	SAFEBOX 32	1
K	TRANSFORMER (650/110VAC 100VA)	ATL	T3045	1
L	TRANSFORMER (650/110VAC 500VA)	ATL	T3068	1
M	TRANSFORMER (650/230VAC 1000VA)	ATL	T3361	1
N	CABLE EXTENSION KIT	HENRY WILLIAMS	2013.043-A1-000	1
P	LIGHT	KNIGHTSBRIDGE	AMLEDW	1
Q	LIGHT SWITCH	CRABTREE	4177 & 4005	1
R	THERMOSTAT	GREENBROOK	TH90T-C	1
S	TERMINAL GN/Y	WEIDMULLER	WPE35N	1
T	TERMINAL ENCLOSURE	WISKA	COMBI 308/5 BK	1
U	HEATER (30W)	PHANNENBURG	PRH030M	1

NOTES:

1. A YELLOW BAND IS REQUIRED TO BE FITTED AROUND THE FSP LOCATION CASE
2. THE FSP LOCATION CASE I.D. IS TO BE FITTED TO EACH SIDE OF THE CASE

	Henry Williams Ltd - Electrical Projects		DARLINGTON ENGLAND
	PRODUCED	Typical Drawings - FSP01-02 B Case (Safebox 32)	
CHECKED	DWG. No M001		
The copyright and all other rights related to this drawing or document remains at all times with Messrs. Henry Williams Ltd. Without their written authorisation it must neither be copied or reproduced nor be communicated or rendered acceptable or profitable in any form to any third parties.			ISSUE

INFORMATION ONLY

SAFEBOX 32

ALL EQUIPMENT INSIDE THE HATCHED LINE IS RATED TO 650V & CLASS II

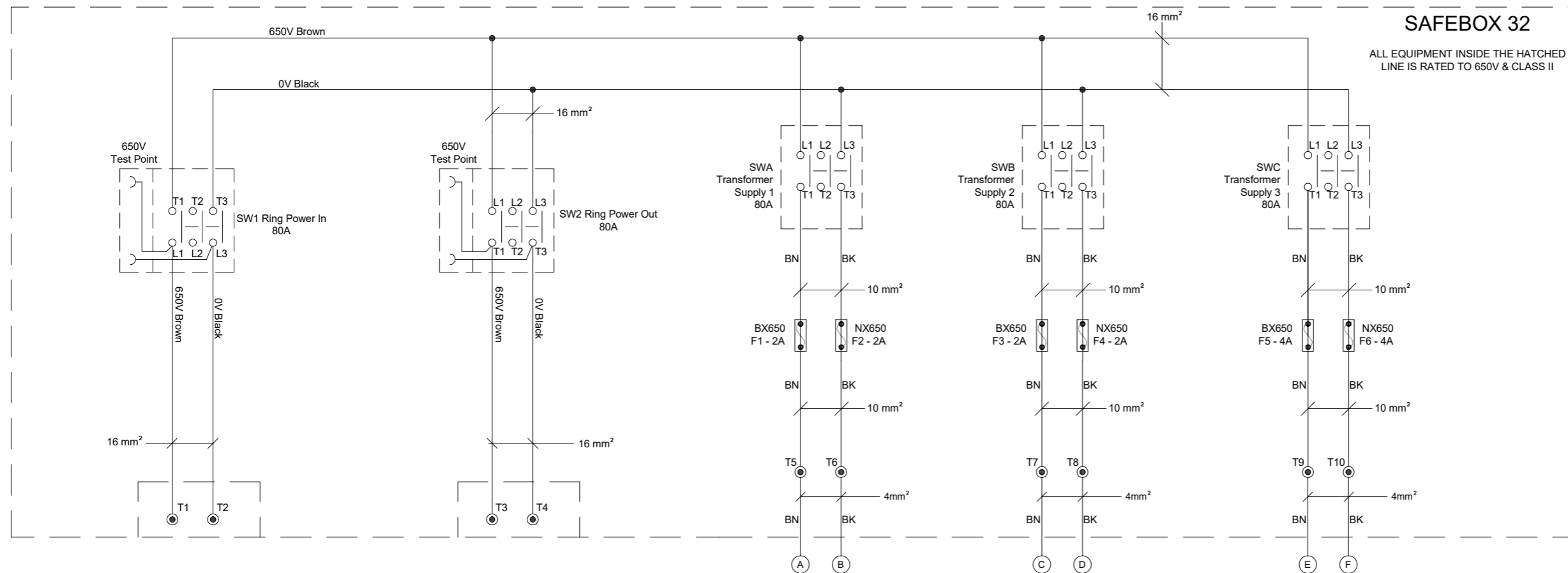

Label to be installed on Earth Bar
EQUIPMENT HAVING EXPOSED CONDUCTIVE PARTS CONNECTED TO EARTH MUST NOT BE BROUGHT INTO THIS INSTALLATION

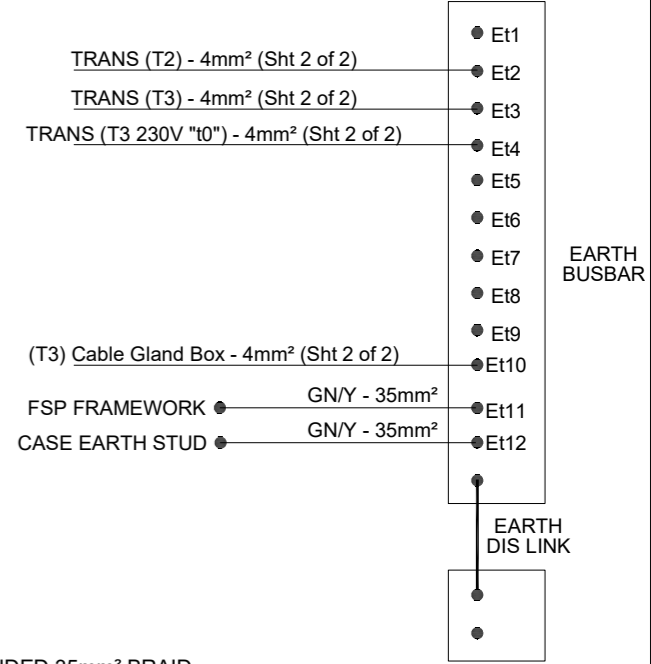
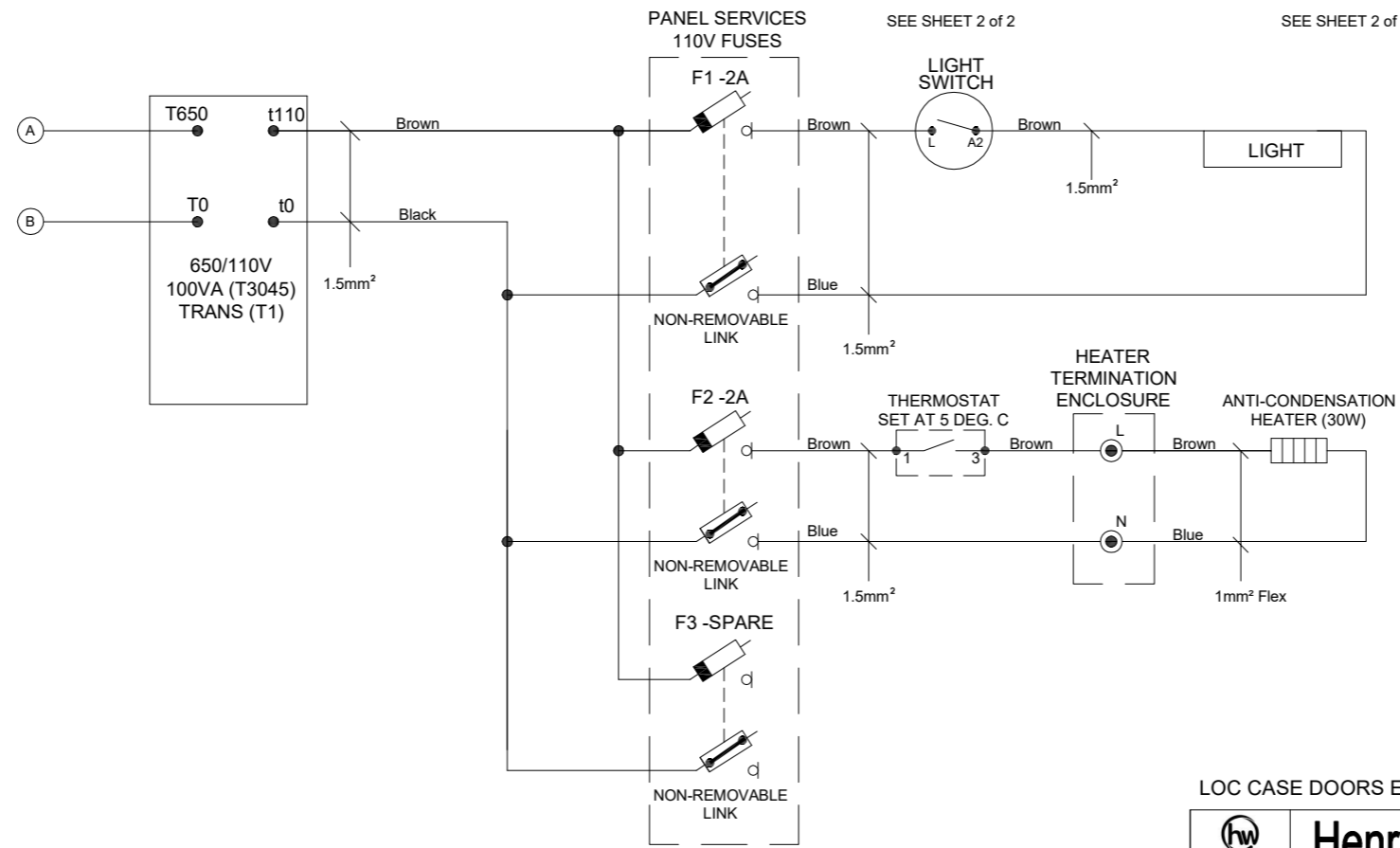

BX110(INT) FUSE	RATING	FUNCTION
F1	2A	LIGHT
F2	2A	HEATER
F3	-	SPARE

LOC CASE DOORS EQUIPOTENTIALLY BONDED 35mm² BRAID

	<h2>Henry Williams Ltd - Electrical Projects</h2>		DARLINGTON ENGLAND
	PRODUCED	<h3>Typical Drawings - FSP01-02 B Case (Safebox 32)</h3>	
CHECKED	ISSUE		

INFORMATION ONLY

The copyright and all other rights related to this drawing or document remains at all times with Messrs. Henry Williams Ltd. Without their written authorisation it must neither be copied or reproduced nor be communicated or rendered acceptable or profitable in any form to any third parties.

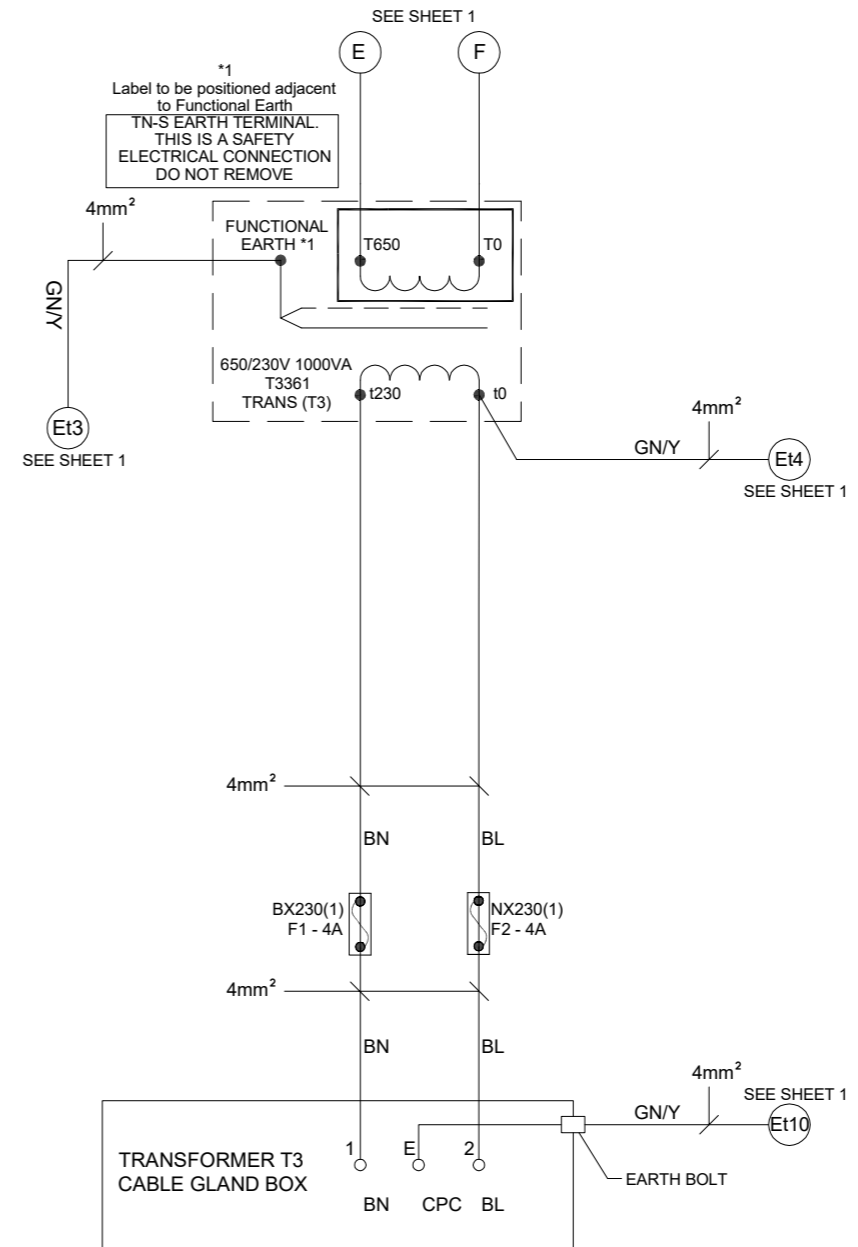
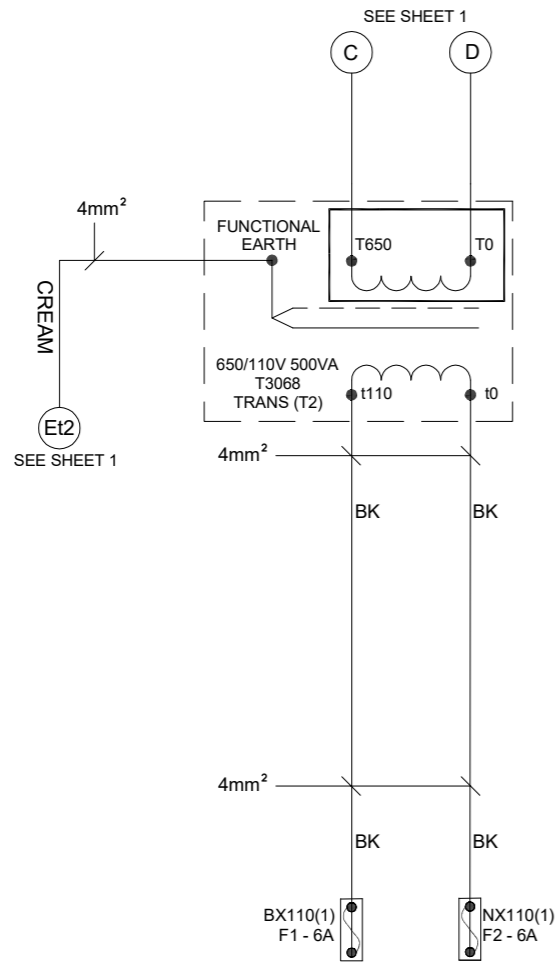

INFORMATION ONLY

 <small>Henry Williams</small>	<h2 style="margin: 0;">Henry Williams Ltd - Electrical Projects</h2>	DARLINGTON ENGLAND
PRODUCED	<h3 style="margin: 0;">Typical Drawings - FSP01-02 B Case (Safebox 32)</h3>	DWG. No <h3 style="margin: 0;">E002</h3>
CHECKED		
The copyright and all other rights related to this drawing or document remains at all times with Messrs. Henry Williams Ltd. Without their written authorisation it must neither be copied or reproduced nor be communicated or rendered acceptable or profitable in any form to any third parties.		ISSUE