

ITEM	DESCRIPTION	MANUFACTURER	PART No.	QUANTITY
A	A1 MILD STEEL LOCATION CASE	HENRY WILLIAMS	2011.075-A1-000	1
B	EARTH BLOCK 10 WAY + 1 x DIS LINK	FURSE	LK243-10	1
C	NOT USED			
D	FUSE CARRIER	CAMASTER	CM63F	1
E	LINK CARRIER	CAMASTER	CM63FW	1
F	MODULAR ENCLOSURE	MCG	92.08	1
G	TERMINAL BAR SUPPORT	MCG	1006.08	1
H	FUSE HOLDER 1P+N	ABB	2CSM200893R1801	3
J	CLASS 2 POWERBOX	HENRY WILLIAMS	SAFEBOX105	1
K	TRANSFORMER (650/110VAC 100VA)	ATL	T3045	1
L	TRANSFORMER (650/110VAC 1000VA)	ATL	T2966	1
M	NOT USED			
N	CABLE EXTENSION KIT	HENRY WILLIAMS	2013.043-A1-000	1
P	LIGHT	KNIGHTSBRIDGE	AMLEDW	1
Q	LIGHT SWITCH	TIMEGUARD	TPSL01	1
R	THERMOSTAT	GREENBROOK	TH90T-C	1
S	TERMINAL ENCLOSURE	WISKA	COMBI 308/5 BK	1
T	HEATER (30W)	PHANNENBURG	PRH030M	1

NOTES:

1. A YELLOW BAND IS REQUIRED TO BE FITTED AROUND THE FSP LOCATION CASE
2. THE FSP LOCATION CASE I.D. IS TO BE FITTED TO EACH SIDE OF THE CASE

	<b>Henry Williams Ltd - Electrical Projects</b>		DARLINGTON ENGLAND
	PRODUCED	<b>Typical Drawings - FSP01-02</b> <b>A Case (Safebox 105)</b>	
CHECKED			DWG. No  <b>M001</b>
The copyright and all other rights related to this drawing or document remains at all times with Messrs. Henry Williams Ltd. Without their written authorisation it must neither be copied or reproduced nor be communicated or rendered acceptable or profitable in any form to any third parties.			ISSUE

INFORMATION ONLY

# SAFEBOX 105

ALL EQUIPMENT INSIDE THE HATCHED LINE IS RATED TO 650V & CLASS II

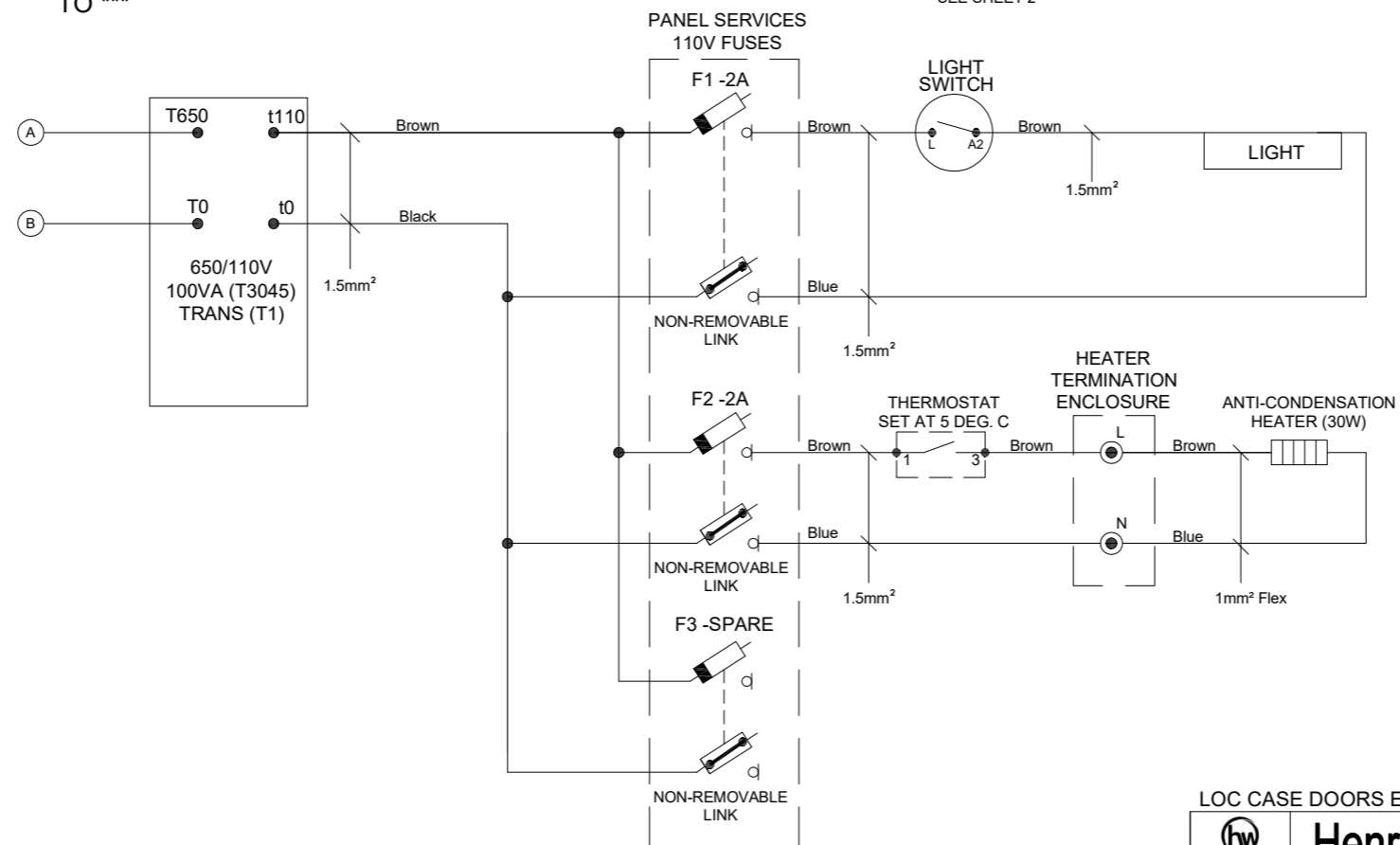
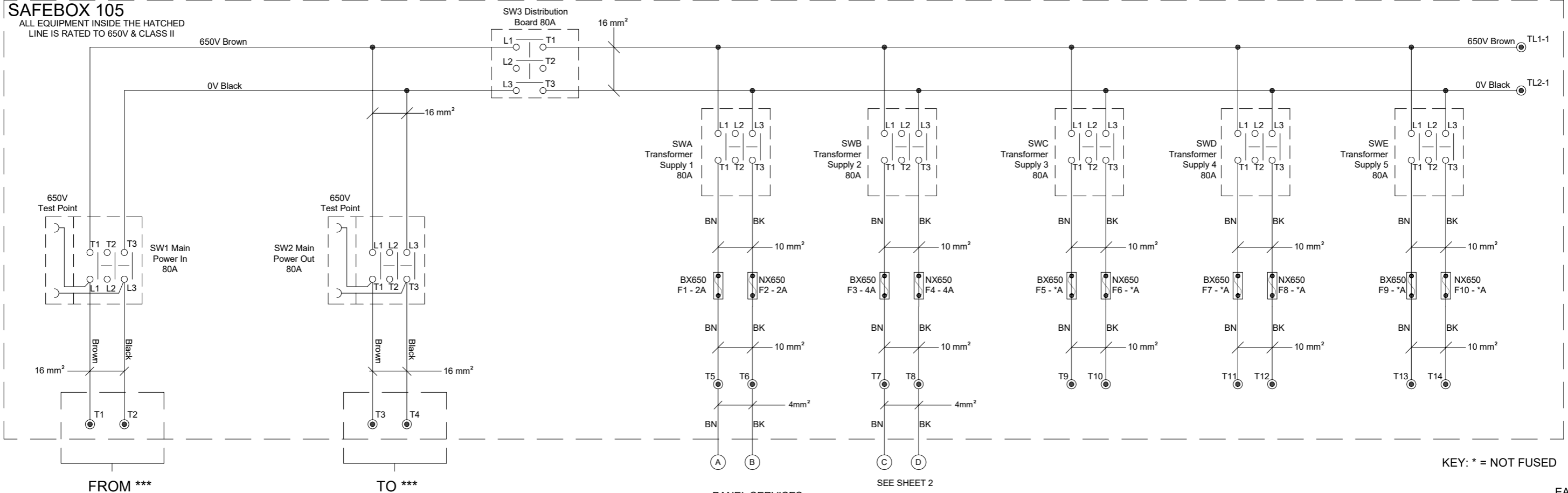

BX110(INT) FUSE	RATING	FUNCTION
F1	2A	LIGHT
F2	2A	HEATER
F3	-	SPARE

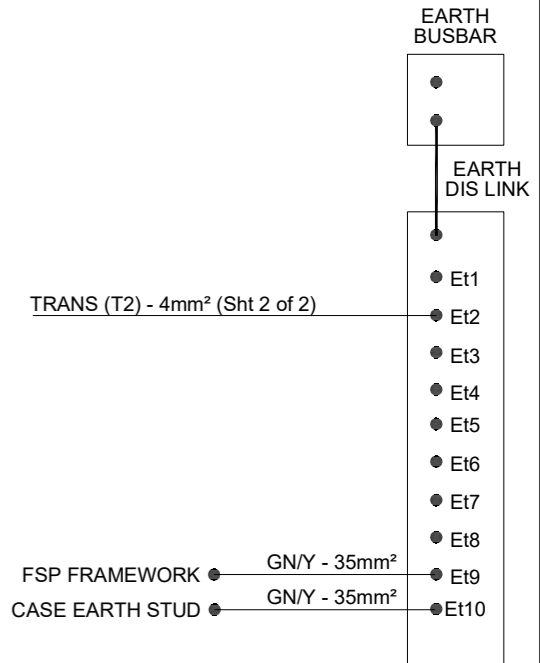

LOC CASE DOORS EQUIPOTENTIALLY BONDED 35mm<sup>2</sup> BRAID

	<h2>Henry Williams Ltd - Electrical Projects</h2>		DARLINGTON ENGLAND
	PRODUCED	<h3>Typical Drawings - FSP01-02</h3> <h3>A Case (Safebox 105)</h3>	
CHECKED	E001		
<p>The copyright and all other rights related to this drawing or document remains at all times with Messrs. Henry Williams Ltd. Without their written authorisation it must neither be copied or reproduced nor be communicated or rendered acceptable or profitable in any form to any third parties.</p>			ISSUE

INFORMATION ONLY

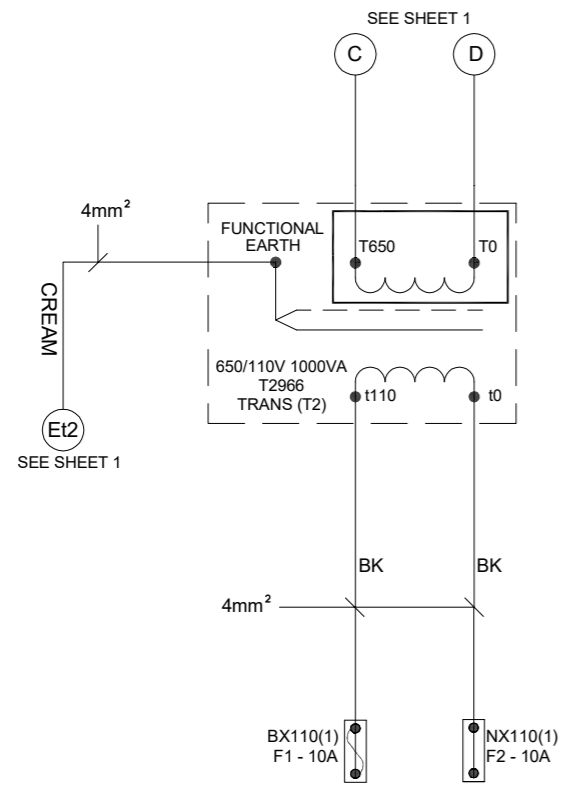

INFORMATION ONLY

 <small>Henry Williams</small>	Henry Williams Ltd - Electrical Projects	DARLINGTON ENGLAND
PRODUCED	<h3 style="margin: 0;">Typical Drawings - FSP01-02</h3> <h3 style="margin: 0;">A Case (Safebox 105)</h3>	DWG. No  <h2 style="margin: 0;">E002</h2>
CHECKED		ISSUE
The copyright and all other rights related to this drawing or document remains at all times with Messrs. Henry Williams Ltd. Without their written authorisation it must neither be copied or reproduced nor be communicated or rendered acceptable or profitable in any form to any third parties.		